

Product: Pilfer – Proof **18 x 12 mm**  
Bottle Neck finish: **DIN 6094-7; GME 305C; GF 305**

#### Shell Material

Al Composition	<b>EN AW-8011A</b> <b>Al Fe Si (A) EN541/EN573-3</b>
Al Condition	<b>H14</b>
Specific gravity g/cm <sup>3</sup>	<b>2.71</b>
Tensile strength Rm MPa	<b>120 - 160</b>
Elongation. A50, % min	<b>≥2.0</b>
Anisotropy, % max	<b>≤2.0</b>
Material Thickness, mm	<b>0.19 ± 0.01</b>

#### Closure Drawing

##### A) without cushioning ring under the perforation line

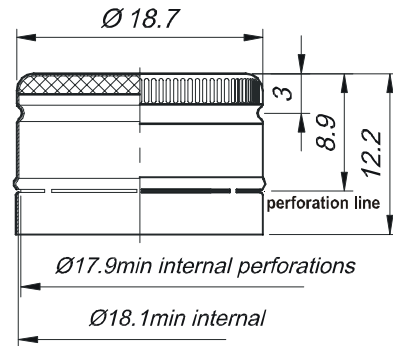

##### B) with cushioning ring under the perforation line

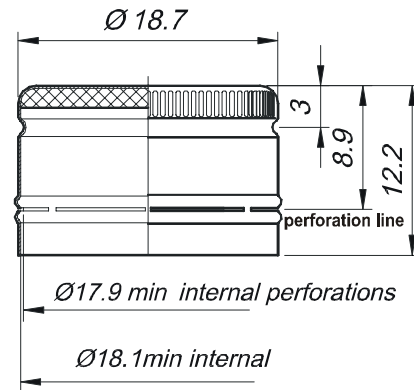

#### Closure Characteristics

Outside diameter , mm	Ø <b>18.7 ± 0.3</b>
Height, mm	<b>12.2 ± 0.2</b>
Inside diameter, mm	Ø <b>18.1 min</b>
Weight without liner, g.	<b>0.50 ± 5%</b>
Internal lacquer type	<b>Modified epoxy</b>
External lacquer type	<b>Modified poliester</b>

Resins obtained from monomers without any phenols or phtalates.

#### Recommended application details:

Head pressure force, N	<b>900-1000</b>
Side roller pressure force, N	<b>50-60</b>
Undertuck roller pressure force, N	<b>50-60</b>

#### Removal Torque:

Bridges Breaking Torque, N.m.	<b>0.35 – 0.9</b>
-------------------------------	-------------------

NOTE: REMOVAL TORQUES ARE DEPENDANT ON VARIATIONS IN GLASS AND APPLICATION CONDITIONS.

#### LINER

Liner material:	Foam polyethylene
Liner thickness, mm	<b>1.4 ± 10%</b>
Liner weight, g	<b>0.09 ± 1%</b>

User has to verify the closures suitability with the specific bottled product and to guarantee the absence of chemical and organoleptic alterations.

#### Food Contact Approval

All materials intended to come into contact with food are in conformity with the European Community directives, the relevant national regulations and the relevant FDA requirements.

All products comply with Commission directive 94/62/EC concerning heavy metals.

All resins and additives used for inside lacquer production comply with the following Regulations:

Commission directive 2002/72/ EC of 6 August 2002 relating to plastic materials and articles intended to come into contact with foodstuffs.

FDA regulation; CFR 21, chapter 175.300 Resinous and polymeric coatings

#### Packaging specification

Quantity, pcs.	<b>16 000 pcs</b>	Pallet type – Euro pallet	<b>Dimension</b> <b>1200 x 800 x*</b>
Box Dimension, mm	<b>600 x 400 x 370 mm</b>	* Height of the pallet may vary with customers' requirements	
Cardboard Type	<b>Corrugated five layer cardboard</b>	Outside packing	<b>Stretch wrapped</b>
Polyethylene Sack	<b>Polyethylene –non-toxic, antistatic</b> <b>&lt;100 ppm Pb, Cd, HgCr<sup>+6</sup></b>	Pallet identification	<b>Labelling</b>
Adhesive Strip (Scotch)	<b>50 mm</b>		
Product Identification	<b>Labelling</b>		

**Notes:** Closures shall be stored in a well-ventilated place avoiding direct sunlight and strong odour for the period of 1 year. Pallets shall not be stacked.