

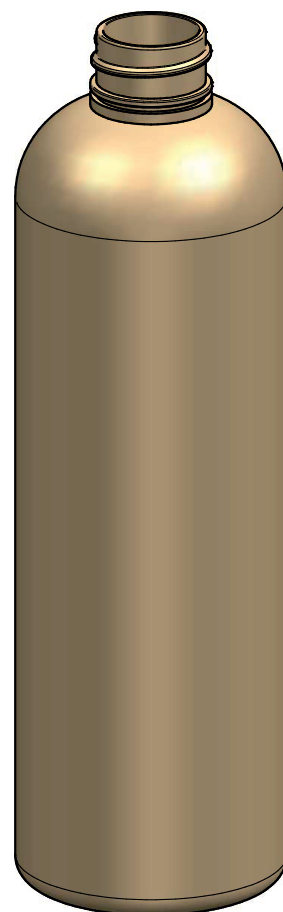

Fill level

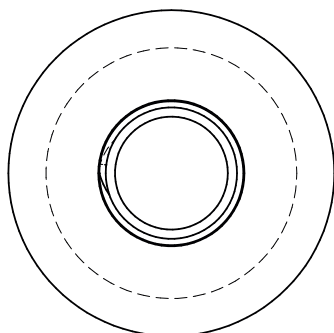
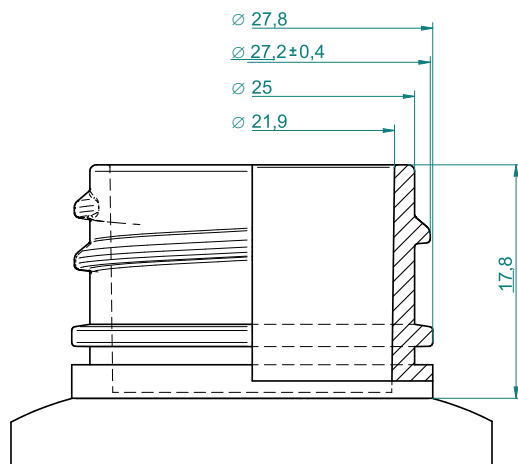
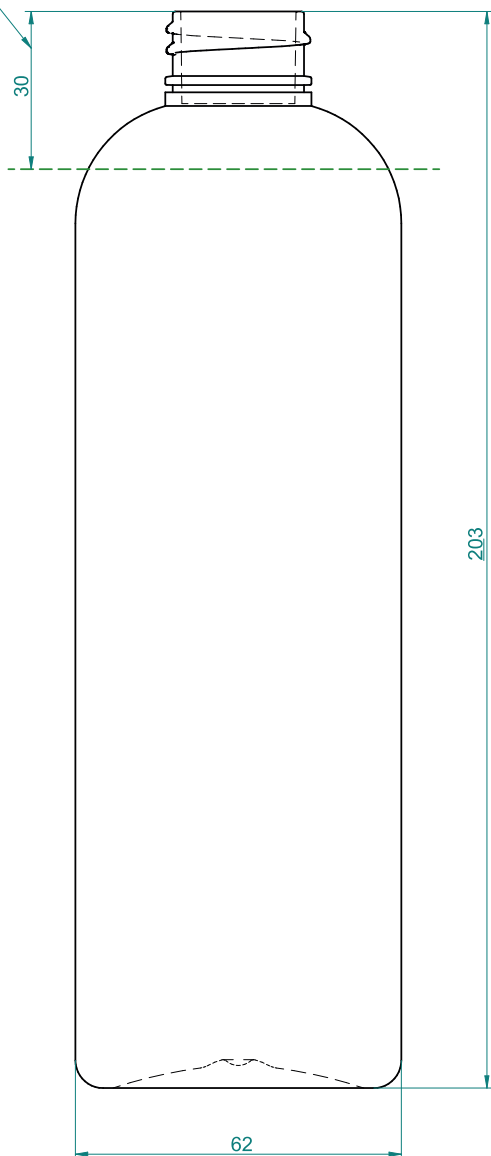

DATE	REVISIONS	CAP. FILLPT.	500 ml			<b>ADPACK</b> group sro	BOTTLE
04/08/2014		CAP. BRIMF.	521 ±15 ml				
		FINISH	28/410	MOLD No.	548285	<b>PET 500</b>	CAT. No
		HEIGHT	203 mm	MACHINE	DG 5 1/2"		
		DIAMETER	62 mm	DATE	04/08/2014	<b>A 5018</b>	
		WEIGHT	40 ±1 g	UNITS PER PALLET	1 944		